

PARALLEL UNIVERSES

19:0

$$Q_k = N \sum J \sum A_{KNJ} U_{KNJ} + N \sum J \sum B_{KNJ} V_{KNJ} + N \sum J \sum C_{KNJ} Z_{KNJ}$$

$$= N \sum S_{KN} + N \sum Q_{KN} + N \sum M_{KN}$$

WHERE,

$$S_{KN} = J \sum A_{KNJ} U_{KNJ}$$

REPRESENTS WAVES U_{KNJ} AT INFINITE ENERGIES E_{KNJ} , AND WHICH ARE EITHER SINGULARITIES OR WIMP (SEE TABLE BELOW).

$$Q_{KN} = J \sum B_{KNJ} V_{KNJ}$$

THE UNIVERSES CHARACTERIZED BY $\Phi_{N,P}$ ARE PARALLEL TO EACH OTHER, THAT IS TO SAY THAT

ALL UNIVERSES SPROUTING FROM A COMMON SOURCE FORM PARALLEL UNIVERSES WITHIN THE SAME HYPERSPACE AND ARE NOT NECESSARILY OVERLAPPING.

$$\Phi_{N,P} \leq \Phi_{N+1,P} \quad \text{OR}$$

$$\Phi_{N,P} \geq \Phi_{N+1,P}$$

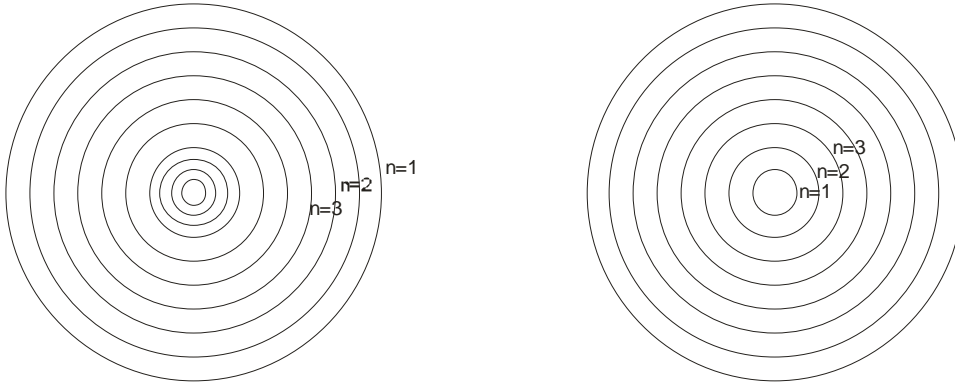

BODIES IN UNIVERSE ARE NOT VISIBLE TO BODIES IN UNIVERSES K-1, K-2, K-3.....BELOW IT

NEVERTHELESS SOME OF THEIR ACTIONS CAN BE FELT ON BODIES BELOW.

SUCH BODIES ARE NORMALLY CALLED GHOSTS.

THE DARK MATTER FORMS SOME SORT OF UNIVERSES SOME OF WHICH OVERLAP OUR UNIVERSE.

PARALLEL UNIVERSE II

THERE ARE OTHER TYPES OF UNIVERSES CHARACTERIZED BY $\Phi_{N,P}$, WHICH ARE PARALLEL TO EACH OTHER, BUT THE NUCLEAR FORCES WHICH STARTED THEIR INDIVIDUAL BIG BANGS ARE DIFFERENT. SUCH UNIVERSES ARE NOT WITHIN THE SAME HYPERSPACE AND ARE NOT NECESSARILY OVERLAPPING.

THE RELATIONSHIPS BELOW DO NOT APPLY TO SUCH UNIVERSES.

$$\Phi_{N,P} \leq \Phi_{N+1,P} \quad \text{OR}$$

$$\Phi_{N,P} \geq \Phi_{N+1,P}$$

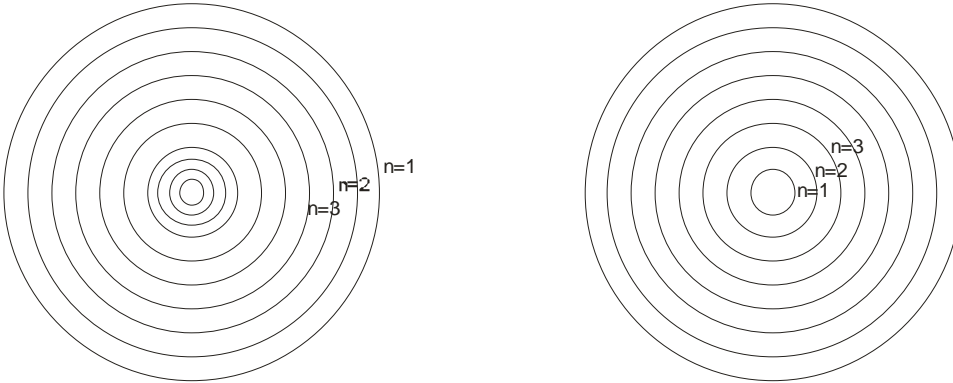

BODIES IN SUCH UNIVERSES ARE NOT VISIBLE TO EACH OTHER NOR TRANSVERSABLE EXCEPT THROUGH SOME SORT TIME MACHINES.

19:2



OVERLAPPING UNIVERSES

20:1

WE RECALL FROM LAST CHAPTER THAT:

$$\Phi_{K=N} = \sum_{J} A_{KNJ} U_{KNJ} + \sum_{J} B_{KNJ} V_{KNJ} + \sum_{J} C_{KNJ} Z_{KNJ}$$

$$= \sum_{K} S_{KN} + \sum_{K} Q_{KN} + \sum_{K} M_{KN}$$

THE UNIVERSES CHARACTERIZED BY Φ_N INTERLACE EACH OTHER, THAT IS TO SAY THAT:

COMMON NODES FORM PARALLEL UNIVERSES ALL WITHIN THE SAME HYPERSPACE.

ALL UNIVERSES SPROUTING FROM A COMMON SOURCE ARE WITHIN THE SAME HYPERSPACE AND ARE OVERLAPPING.

$$\Phi_N \leq \Phi_{N+1} \text{ OR}$$

$$\Phi_N \geq \Phi_{N+1}$$

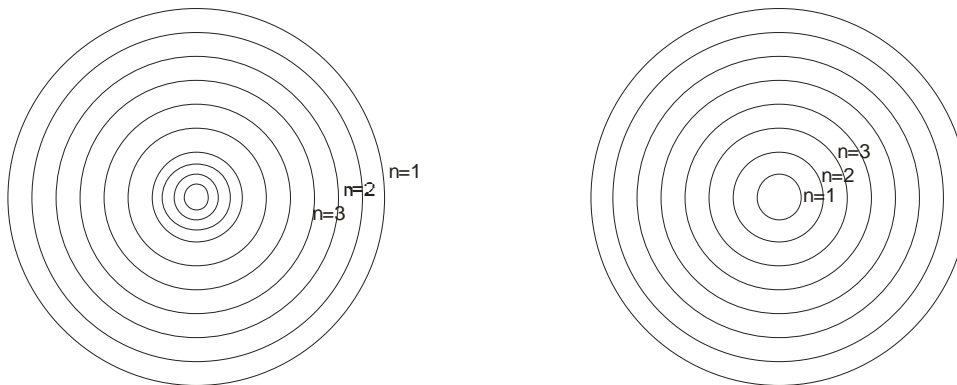

BODIES IN UNIVERSE ARE NOT VISIBLE TO BODIES IN UNIVERSES K-1, K-2, K-3.....BELOW IT

NEVERTHELESS SOME OF THEIR ACTIONS CAN BE FELT ON BODIES BELOW.

SUCH BODIES ARE NORMALLY CALLED GHOSTS.

THE DARK MATTER FORMS SOME SORT OF UNIVERSES SOME OF WHICH OVERLAP OUR UNIVERSE.

20:1

